

# Manual de instalación

## ERM2637

VESA: 200x200

Para pantallas de: 26"-37"

Peso máximo: 25 kg.

Separación Min.-Max.: 6cm - 37cm

### Accesorios

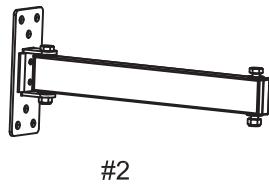
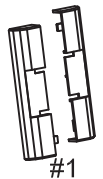
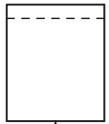

M8x50mm  
[A]x6

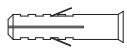

ø10xø8x50mm  
[B]x6



D4  
[C]x4



D6  
[D]x4



D8  
[E]x4



M4x12mm  
[F]x4



M6x12mm  
[G]x4



M8x25mm  
[H]x4



D8x14mm  
[I]x4



Llave  
[J]x2

### Herramientas necesarias

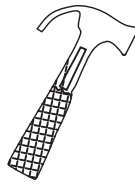
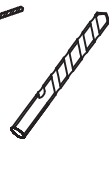
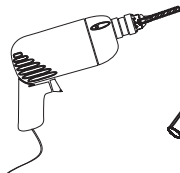
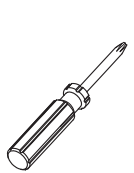

### Paso-1:

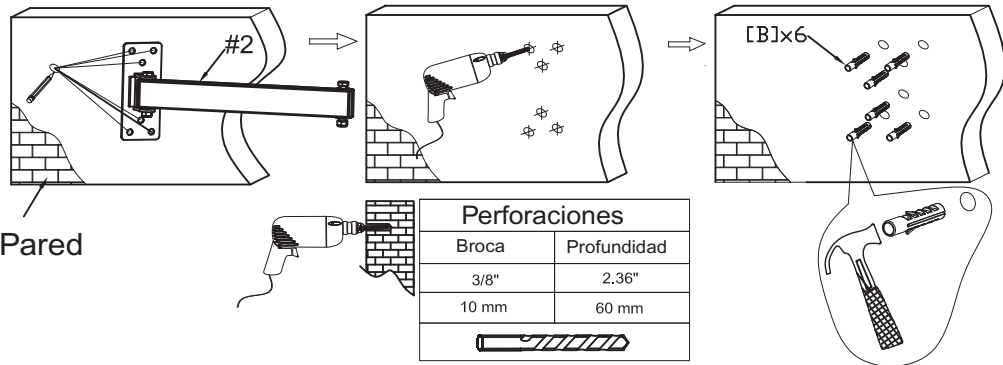

### Paso-2:

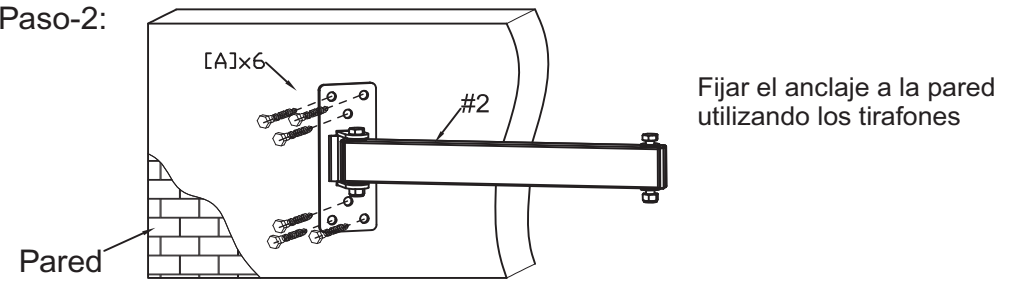

### Paso-3:

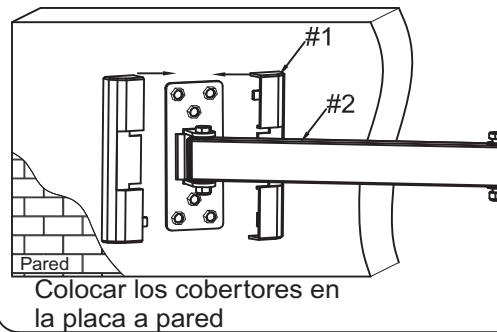

### Paso-4:

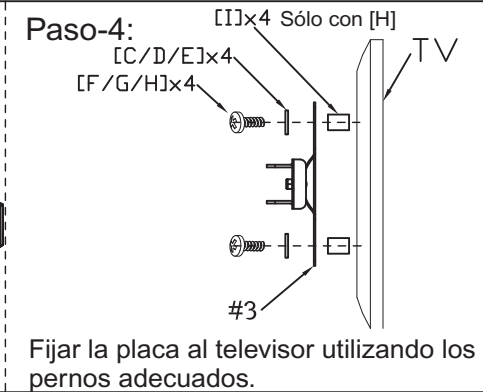

### Paso-5:

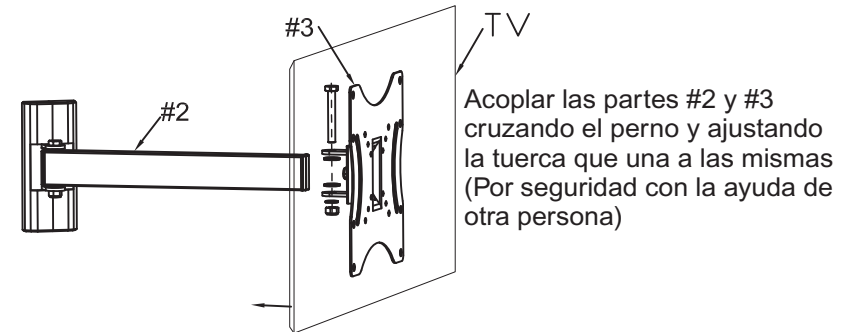

### Paso-6:

